

WWW.MFSTRAATMAN.COM

# Mooring & Berthing Systems



Mooring & Dredging Equipment

# Straatman BV

With more than 50 years experience providing products for the maritime industry, Straatman is an established and well known manufacturer and supplier of mooring, berthing and dredging equipment.

We have developed a sophisticated solar power system for use in the maritime market and have recently extended our product portfolio with the Smart Bollard. We pride ourselves in offering turn-key solutions, including integration and communication with port management systems.

Throughout the years we have continuously developed our products to match industry needs with the latest technology, providing innovative solutions to all major dredging companies, ports, and oil & gas clients around the world.

We design, manufacture and test all Straatman products at our factory in the Netherlands, this keeps the lines short and enables us to maintain high quality products and efficient processes.

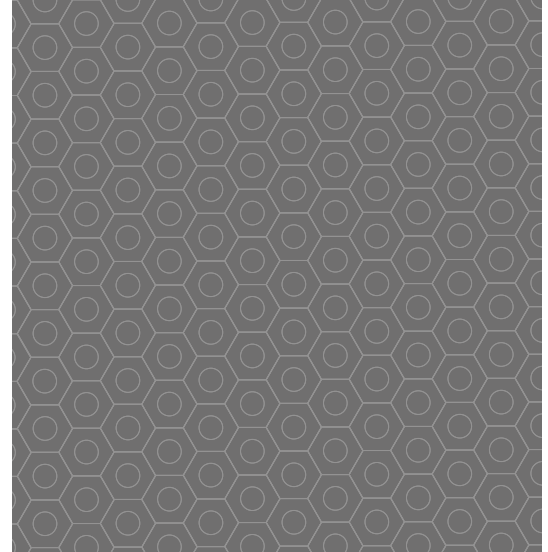

2

## What to expect from us:

High quality products and excellent level of service.

Over 50 years experience in the maritime industry.

In-house design and production in the Netherlands.

Turn-key project supplier.

Continuous innovation and improvement.

Certified to all required industry standards.

Dedicated and enthusiastic team of highly skilled and happy employees.

A commitment to deliver exactly what we promise.

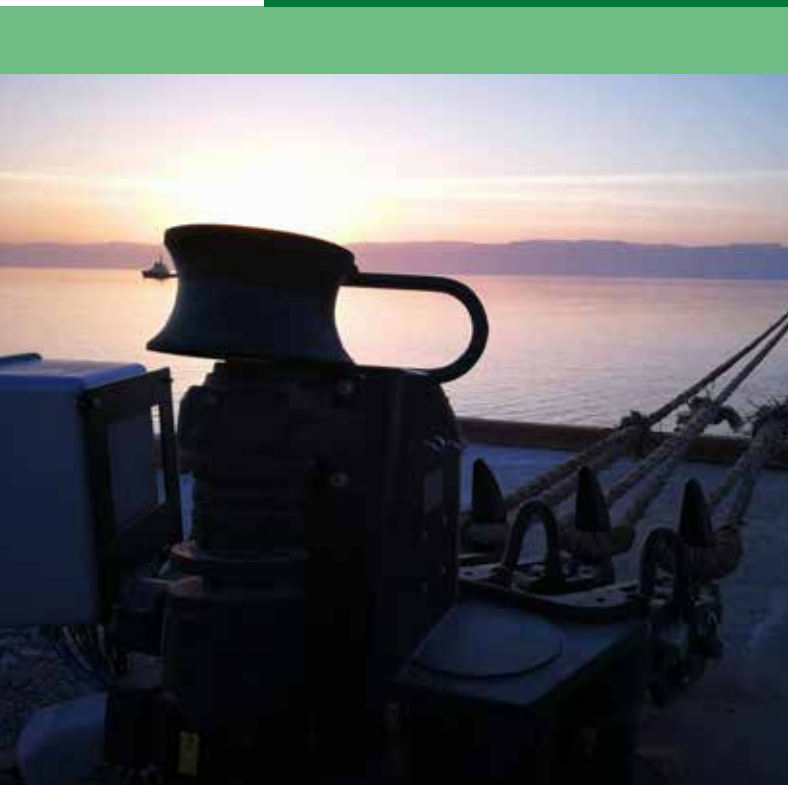

# Product overview Mooring & Berthing Systems

Quick Release Mooring Hooks	4 - 6
Quick Release Mooring Hooks options	7
Single Quick Release Mooring Hooks	8
Double Quick Release Mooring Hooks	9
Triple Quick Release Mooring Hooks	10
Quadruple Quick Release Mooring Hooks	11
Quick Release Mooring Hooks for Mooring Buoys	12
Quick Release Offshore Hooks FPSO and FSRU	13
Capstans	15
Berthing Aid Systems (BAS) and Environmental Monitoring Systems (EMS)	16
Mooring Load Monitoring Systems (MLMS)	17
MoorControl, software integration	18
Solar Power Systems	19
Smart Bollard	20
Quick Release Towing Hooks	21
Tests and Certificates	22
Service and Support	23



# Quick Release Mooring Hooks

In demanding maritime situations, safe and reliable mooring hooks are a necessity. Our Quick release Mooring Hooks are especially designed to guarantee safe and efficient mooring operations at oil, gas, chemical, iron, coal and grain terminals. All hooks are available in single and multiple assemblies and can be equipped with different kinds of options.

## We assure safety of our Quick Release Mooring Hooks

With more than 50 years experience in the design and manufacture of mooring equipment, our Quick Release Hooks have been installed all over the world in several kinds of industries. Our products have proven their worth in practice, as Straatman have become a leading manufacturer of mooring solutions.

All Quick Release Hooks are compliant with OCIMF MEG4, BS6349-4 and PIANC153 guidelines.

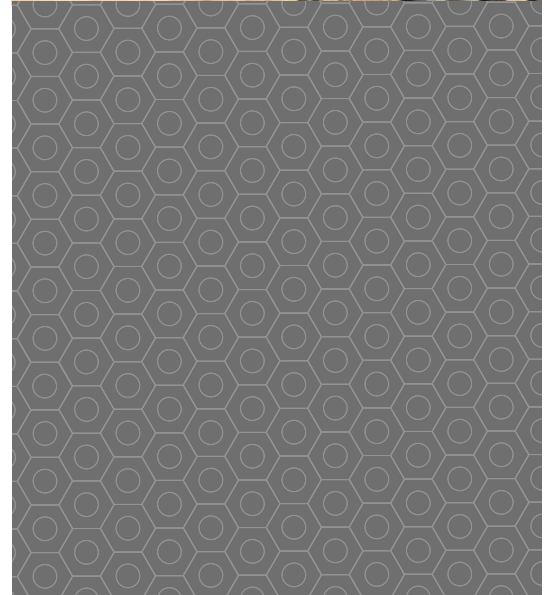

## All components of our quick release hooks are designed with safety in mind:

- Our quick release hooks can swivel freely, ensuring complete spark-free operation.
- The electrical equipment can be fully certified for hazardous environments.
- Smart designs result in a safe and easy operation of the quick release hooks and capstans.
- Integration with our software solutions will reduce risks.

## Our customers

We do what we promise!

---



---

*We declare that Straatman has satisfactorily completed engineering, production and implementation of the quick release hooks and independent power supply by solar panel for the project "Mooring and berthing dolphins Calandkanaal" in the port of Rotterdam*

---



---

*"Recently our company placed an order with Machinefabriek L. Straatman for a project involving Quick release Hooks Systems. The equipment supplied was of high quality and the delivery was punctual. We are satisfied by their work and their technical assistance and we are looking forward to work with this company again for future projects"*

---



---

*Eiffage genie Civil Marine would like to thank Straatman BV for all the efforts provided to deliver the QRH for the GTA HUB Terminal project. Furthermore, please be insured that Eiffage Genie Civil Marine will keep in his records that Straatman BV is a valued partner and that we will keep you in our Bidder-list for supply of QRH for future projects"*

---

Please send an email to [info@mfstraatman.com](mailto:info@mfstraatman.com) if you would like to receive a project reference "highlight" list

# Quick Release Mooring Hooks



## Traceability

Each vital part is stamped with a unique number so as to ensure traceability to the material certificate.

## Manual release lever

All Quick release hooks can be released manually with an effort of  $\pm 20$  kg at full load.

## Counter balanced hook

The hook parts are made of forged steel and are counterbalanced. The hook can easily be reset by means of one simple rotation movement.

## Self supporting

All hooks are self supporting. All movements are limited to prevent contact with the structure.

## Locking device

The locking device prevents accidental release and confirms a positive reset.

## Base plate

The base plates are made of high quality steel. Custom made base plates to fit existing bolt patterns are available on request.

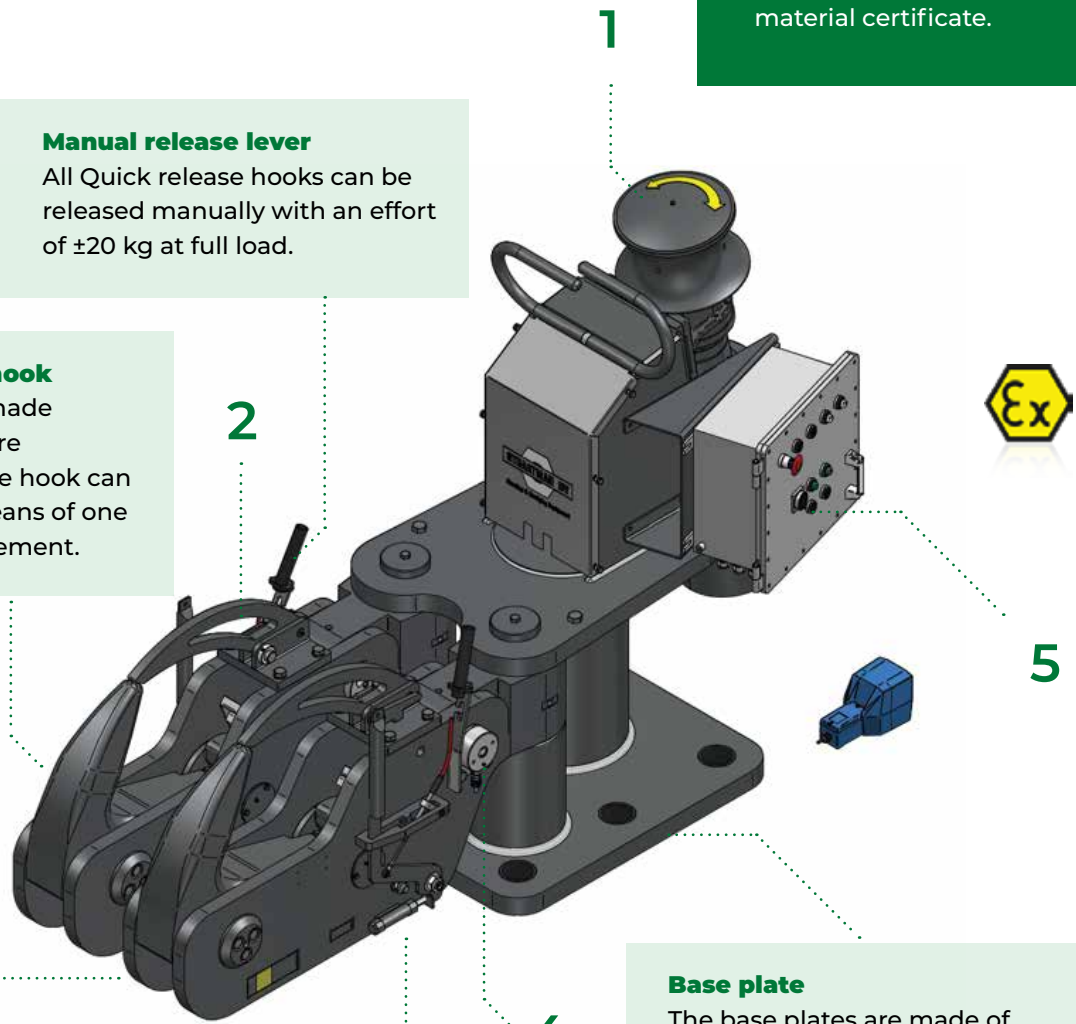

# Quick Release Mooring Hook options



**1. Integrated vertical capstan.** The capstan allows hauling in of the mooring line in a safe and efficient way.

**2. Rope keeper** In some specific situations, there is a risk of the mooring or towing rope slipping off the quick release hook. For example, on anchoring pontoons or mooring buoys that are subjected to waves. In order to avoid this risk, all quick release mooring hooks can be equipped with a device that prevents the rope from slipping.

**3. Remote release** All quick release hooks can be equipped with a electric or electric-hydraulic release mechanism. In the event of a breakdown or failure, it is possible to open the hooks on the unit manually. A demountable lever prevents accidental opening.

**4. Mooring Load Monitoring system** with inhook load cell calibration facility (Page 17), locally and remote controlled by our MoorControl software (page 18).

**5. Explosion proof version components** for hazardous zone, in conformance with ATEX, IECEx and Class I division 2.

**6. Stand alone autonomous solar power supply system** (page 19)

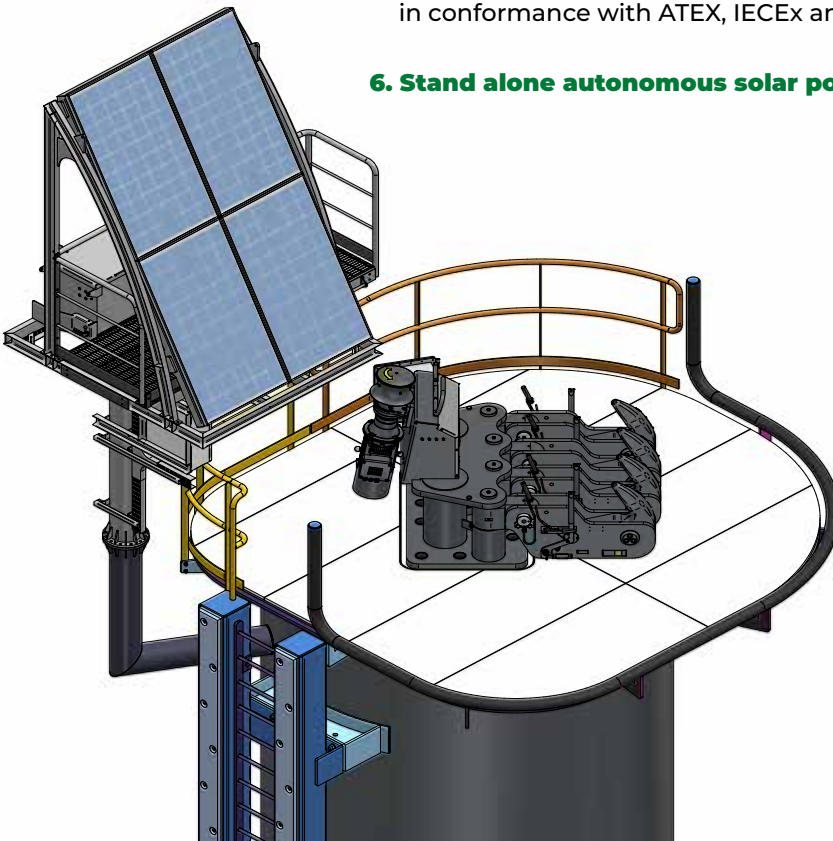

# Single Quick Release Mooring Hooks Units

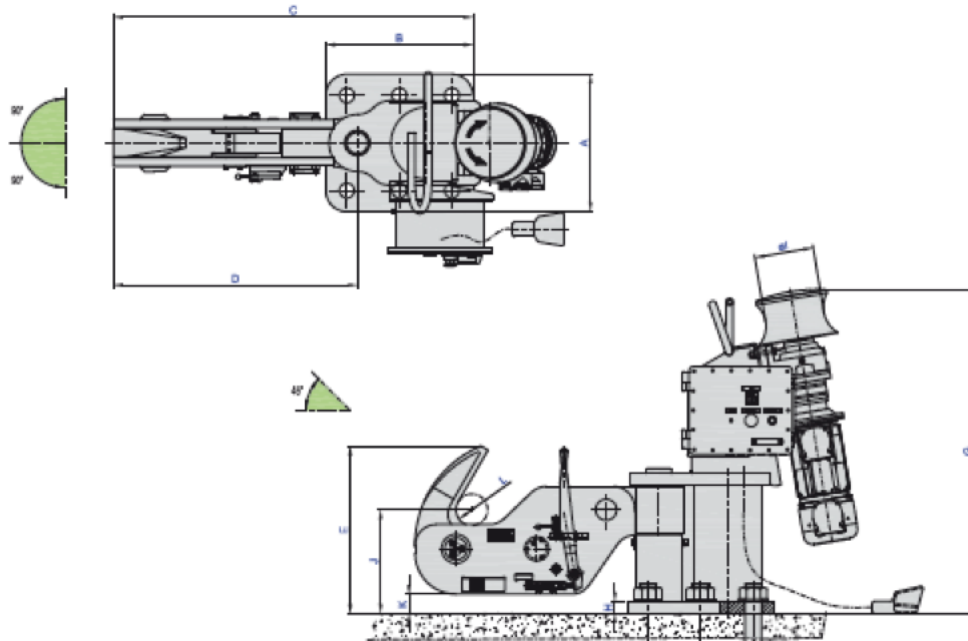

8

	40 ton	60 ton	75 ton	100 ton	125 ton	150 ton	200 ton
A	600	650	650	650	650	650	650
B	600	650	650	700	700	700	865
C	1266	1543	1573	1734	1709	1960	2160
D	785	1043	1073	1179	1160	1420	1415
E	585	705	705	790	790	860	860
F	n.a.	n.a.	n.a.	n.a.	n.a.	n.a.	n.a.
G*	1400	1400	1400	1400	1400	1400	1400
H	35	45	45	50	55	60	65
I	280	280	280	280	280	280	280
J	358	440	440	490	490	535	535
K	90	90	90	90	90	90	90
L	96	130	130	150	150	150	150
Anchors	4 x M48	6 x M48	6 x M56	6 x M56	6 x M64	6 x M72	6 x M90
Weight**	310	520	600	800	900	1275	1400



# Double Quick Release Mooring Hooks Units

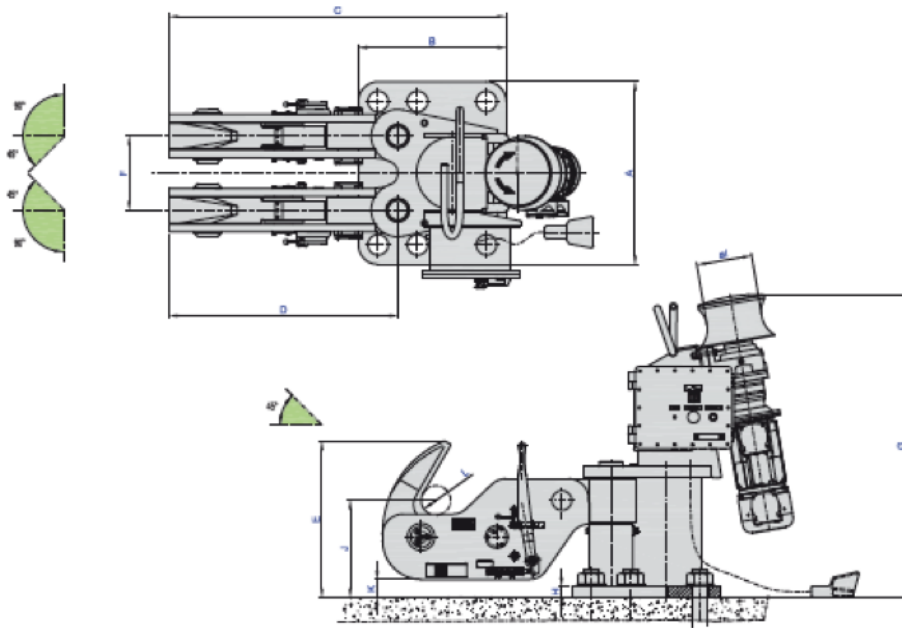

9

	<b>40 ton</b>	<b>60 ton</b>	<b>75 ton</b>	<b>100 ton</b>	<b>125 ton</b>	<b>150 ton</b>	<b>200 ton</b>
A	700	780	900	925	925	1000	1000
B	650	750	750	750	750	1020	1150
C	1233	1558	1610	1729	1709	2160	2157
D	788	1043	1075	1179	1160	1415	1415
E	550	705	706	790	790	864	860
F	300	330	350	375	375	430	425
G*	1400	1400	1400	1400	1400	1400	1400
H	35	45	45	50	55	60	65
I	280	280	280	280	280	280	280
J	358	440	440	490	490	590	535
K	90	90	90	90	90	90	90
L	96	130	130	150	150	150	150
Anchors	6 x M48	6 x M56	6 x M64	6 x M72	6 x M80	7 x M80	7 x M100
Weight**	500	890	1070	1450	1620	2350	3200

# Triple Quick Release Mooring Hooks Units

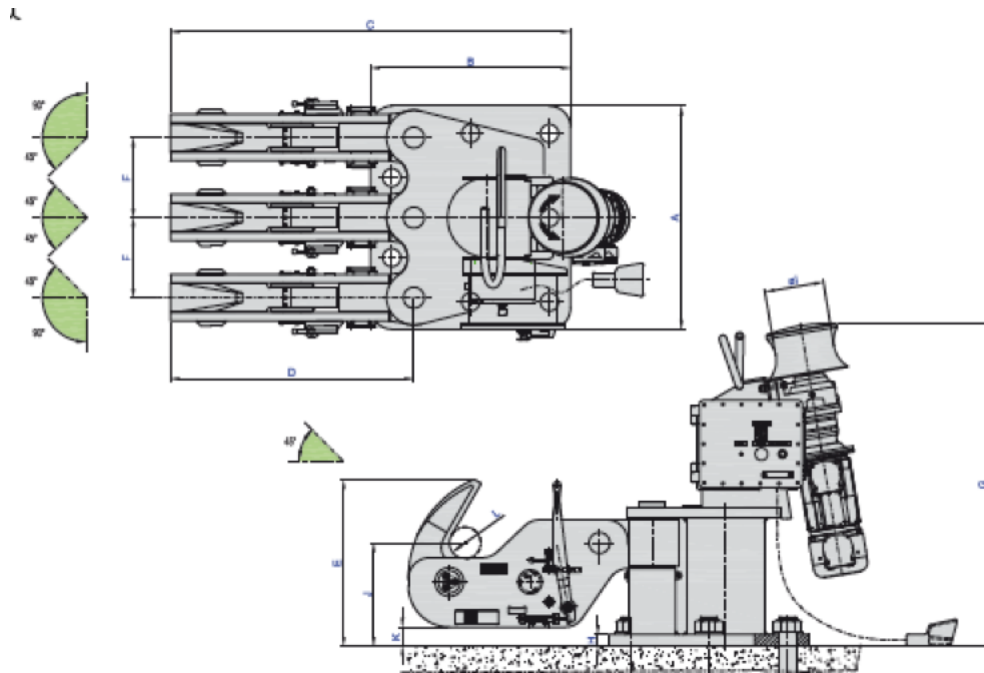

10

	40 ton	60 ton	75 ton	100 ton	125 ton	150 ton	200 ton
A	800	950	1000	1060	1110	1200	1200
B	700	800	850	900	900	1020	1020
C	1266	1688	1745	1880	1860	2190	2240
D	788	1043	1075	1180	1160	1415	1415
E	550	711	705	790	790	864	760
F	300	330	375	390	425	430	625
G*	1400	1400	1400	1400	1400	1400	1400
H	35	50	45	50	55	60	65
I	280	280	280	280	280	280	275
J	358	440	440	490	490	540	535
K	90	90	90	90	90	90	90
L	96	130	130	150	150	150	150
Anchors	6 x M56	6 x M64	6 x M72	7 x M72	7 x M80	7 x M90	7 x M120
Weight**	715	1275	1560	2160	2470	3700	4000

# Quadruple Quick Release Mooring Hooks

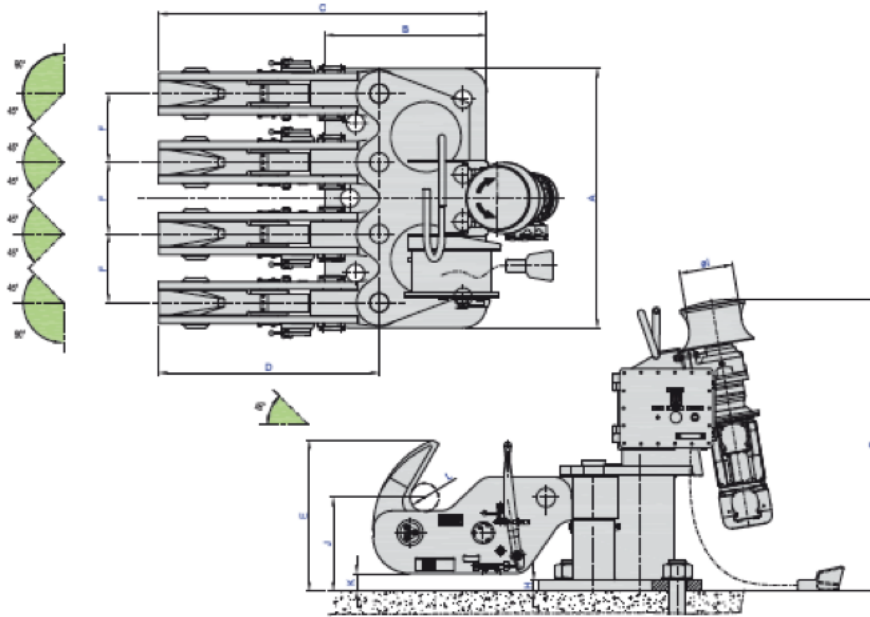

11

	40 ton	60 ton	75 ton	100 ton	125 ton	150 ton	200 ton
A	1185	1350	1400	1450	1400	1670	2250
B	750	750	800	850	850	1025	1100
C	1340	1593	1675	1809	1784	2155	2200
D	785	1043	1075	1180	1160	1415	1415
E	585	705	705	790	790	860	860
F	300	330	350	375	375	450	625
G*	1400	1400	1400	1400	1400	1400	1400
H	45	45	45	50	55	60	65
I	280	280	280	280	280	280	275
J	358	440	440	490	490	540	535
K	90	90	90	90	90	90	90
L	96	130	130	150	150	150	150
Anchors	7 x M64	7 x M72	7 x M80	7 x M90	7 x M90	9 x M80	9 x M120
Weight**	940	1690	2060	2850	3200	4500	4800

Apart from our wide range of standard hook configurations, we also produce special configurations such as back to back, 'V' formation, and up to sextuple hook foundations.

# Quick Release Mooring Hooks for Mooring Buoys

Our quick release mooring hooks type GMH are often used on Mooring Buoys. As a standard they are equipped with a rope keeper, a device to avoid the accidental slip of mooring lines, potentially caused by waves.

## Options for mooring buoy hooks:

Operating a mooring hook on a buoy can be a dangerous activity. Especially in bad weather conditions or in the unlikely situation that the quick release hook need to be released under load. Through years of experience and evaluating feedback from our clients, we have developed a wide range of options. All these options are dedicated to the safety of the mooring operators.

## All our hooks can be executed with the following options:

- Remote release.
- Load monitoring.
- A solar power system.
- Explosion proof components in accordance with ATEX/IECEx.
- Handheld monitoring devices.



## Telemetry system

We have developed a sophisticated telemetry system enabling the port operators to control their mooring buoys from a safe distance.

Integrated load monitoring software;

Integrated remote release software;

A sophisticated logging functionality, storing all alarms, data and activities per vessel;

A portable device showing all integrated software, even suitable for a hazardous area (ATEX certified).

Using the Straatman Telemetry System for Mooring Buoys will lead to:

Increased safety of operators, equipment and environment;

The possibility to respond quickly in unsafe situations;

Insight into mooring data which will lead to improvements.





## Quick Release Offshore Hooks FPSO



With years of experience in manufacturing and delivering hooks to the offshore Oil & Gas and maritime industries, we have a deep understanding of the market, its requirements, the necessary documentations and certifications.

Based on our “standard” quick release mooring hook we have developed a special design used on FPSO's for Tandem Mooring and Offloading operations.

The Straatman FPSO hook, or so called Hawser hook, is mostly executed as a single fixed hook configuration, integrated with a bracket or foundation to be mounted on a deck surface. This can be done by either welding or bolting. Most common safe working load (SWL) for FPSO hooks is 250 or 300 tons. On request we can design and produce hooks for even higher capacities.

## Quick Release Offshore Hooks FSRU

Typical for FSRU quick release mooring hooks is that the hooks are located on the deck of a FSRU. Using our quick release mooring hooks ensure safe side by side mooring with other vessels or terminals.

### Basic features of our offshore Quick Release Hooks:

- Manual and Remote Release.
- Load Monitoring.
- Custom foundations.
- All components are certified according to ATEX or IECEx, in order to meet the requirements of hazardous environments.
- Monitoring panels / cabinets to be located in the control room.

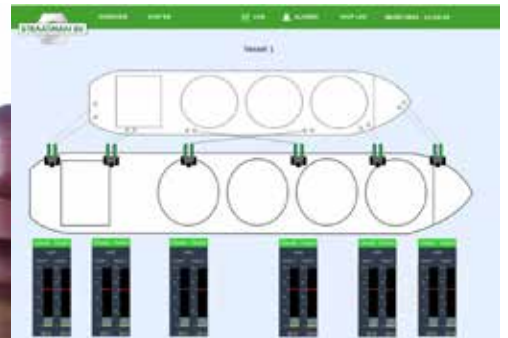

**Straatman supplies complete mooring systems for LNG market. With many years of experience we have a deep understanding of the market and its needs.**

---



# Capstans



Mooring capstans are used for safe and efficient handling of the mooring lines. Although they are mostly supplied as an integrated part of our quick release mooring hook units, they are often produced as free standing vertical capstans. In these cases they are used in combination with bollards or basic quick release hooks. Our standard range of capstans are driven by high-quality electric motors.

## Technical specifications of our standard capstans

- Nominal pull: 10-30 kN.
- Line speed: 10-30 m/s.
- Capstan head diameter : 275 mm.
- Brake or mechanical back stop.
- Switch box and foot switch are included.
- Preservation in accordance with DIN EN ISO 12944, C5.

## Options

- Custom made design.
- 2 rotation directions.
- Electrical brake.
- ATEX / IECEx / Class I division 2 certified for hazardous areas.



Our standard range of capstans are driven by high quality electric motors. If it is not suitable or possible to power the capstan with a standard power supply, our autonomous solar power systems offer the perfect solution, in particular for dolphins located in open water.

# Custom-made capstans

Thanks to our multidisciplinary knowledge and high-tech machinery, we can produce any kind of capstan construction. We offer a wide range of modification options for capstans, varying in size, power, material, and added features. We combine safety, efficiency and durability into all of our custom-made capstan designs.

# Berthing Aid Systems (BAS)

A Berthing Aid System (BAS) or Docking Aid System (DAS) helps reduce risks during berthing as it provides real-time information for safe navigation.

The Straatman Berthing Aid System is based on the latest laser and LED technology. A laser system will measure the distance from the jetty to the side of the approaching vessel. The measured values, like distance (Bow and Aft), speed of approach and angle of approach, are shown in the control room and on a large display on the jetty. We offer a wide range of additional possibilities such as wireless communication to a tablet and advanced pager systems.

### Features of BAS software:

- Vessel database.
- Drift mode.
- Berthing.
- Logging (data will be stored for minimal 6 months).
- Easy integration with Quick Release Hooks, Loading arms, Weather, Wave and Current systems.



# Environmental Monitoring System (EMS)

As an integrated solution, the Berthing Aid System can be extended with the environmental monitoring system (EMS). The most basic option consists of a wind speed and direction sensor. However, often more sensors are added, in order to provide the pilots and operators with meteorological data or defining the operational limits, therefore increasing the overall safety. Most sensors are available for hazardous areas should this be required. For oceanographical data, the standard instrumentation consists of a wave, tide and current sensor. The instrumentation offered is robust and has been designed with minimal maintenance requirements.





# Mooring Load Monitoring System (MLMS)

The Straatman mooring load monitoring system (MLMS) is a system that shows continuous measurement of the load on the Quick Release Hooks. The Quick release Hooks are equipped with a load cell, to measure the mooring loads on each separate hook.

Visualization, history of the mooring loads and the alarms set by the client, are integrated in our MoorControl software platform. Once a vessel is moored, the actual load value of each load cell will be sent to the monitoring software. The online dashboard shows the data of the load on each line and when the maximum load limits are exceeded, the operators will be warned immediately.

## The mooring loads and alarms can be viewed and recorded on displays in various ways:

- On the hook itself.
- In the control room.
- Integrated in a control panel (in combination with remote control).
- Handhelds / tablets.

## Unique: In-hook loadcell calibration facility

The hooks are designed to allow an in-hook load cell calibration. This feature enables calibration- and linearity- check without the necessity to remove the load cell.



## Remote control

The remote release option can be integrated in a remote control system. A control panel located in the control room, can be provided with a variety of controls, such as:

- An individual hook release indicator lamp.
- An individual hook release push button.
- An assembly release push button (all hooks of one mooring hook unit).
- A signal lamp test switch, power on/off switch.
- A power on/off indicator lamp.



# MoorControl

## Supervising your mooring operations efficiently through one software platform

We have all the in-house expertise to supply turn-key projects, including integration and communication to third party Port Management Systems. We can also supply our own online software portal which gives access to your data.

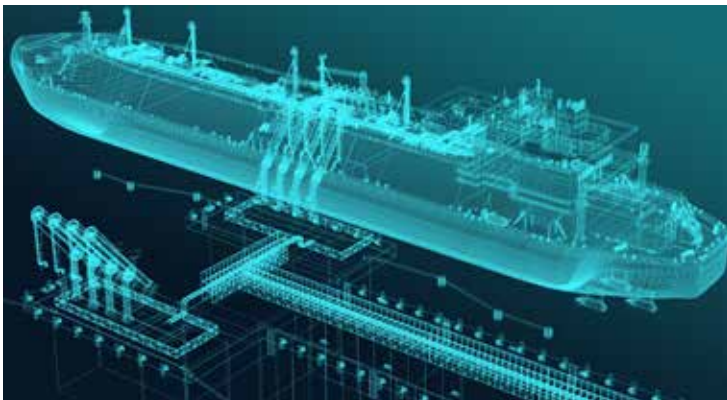

## Why is system integration so important?

- Optimises productivity by integrating all systems.
- Creates an overall view of all mooring and berthing operations.
- Allows for Straatman to be a single point of contact for questions and support.

We are experts in advanced, high-tech communication systems. Our systems can be equipped with dataloggers and can transmit data using LoRa, UHF, Wi-Fi and 4G.



18

## Create an overall view

By integrating all mooring and berthing systems into one easy to operate system, Straatman can provide you with an overall view of your mooring operations. There are a number of different ways to present the data to the operators, such as tablets, mobile phones, control room displays, and handheld pagers. With our MoorControl software platform, the following information can be viewed:

- Historical data (up to 24 months).
- AIS information.
- Vessel database.
- Alarm settings.
- Mooring Load Monitoring System (MLMS).
- Berthing Aid System (BAS).
- Environmental Monitoring System (EMS).



# Solar Power Systems

---

Straatman has developed a sustainable, autonomous solar energy solution which is the perfect solution in situations where a regular power supply by means of cables, is not practical or may not be possible. This high quality green power supply system operates with virtually no downtime. It is designed to endure harsh and demanding environments and provides a guaranteed and continuous availability of power.

For hazardous area applications such as LNG or oil & gas terminals, we can supply fully compliant explosion proof solar power systems, certified to the latest ATEX and IECEx standards.

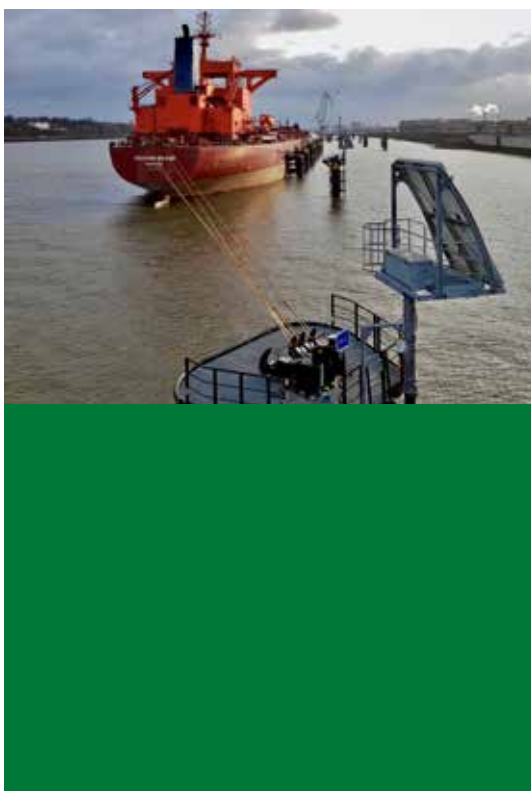

## Benefits of our Solar Power Systems

Guaranteed availability of power;



Low maintenance;



Reduction of energy costs;



Intrinsic safety;



Environmental contribution;



Robust design;



Increased safety in operations;



Remote monitoring;



Eliminates damage to power cables by anchors or dredgers;



Fits perfectly in the vision of sustainability;



No need for fuel.



# Smart Bollard, a Straatman innovation!

The Smart Bollard is a mooring bollard that measures the vector load and angle acting on the bollard from the mooring lines. It uses industrial sensors inside the bollard to sense the loads of the mooring lines, and translates the structural movement caused by the mooring line tension.

With the Smart Bollard, safety can be monitored in real-time. The actual data will be available for the port authority, terminal operator or the vessel itself. It can be used for the mooring of all seagoing vessels, such as container and bulk carriers.



## Benefits of using Smart Bollards:

- Increased safety for operators and assets, thanks to real-time load monitoring and predicted forces.
- Gives a complete overview of mooring forces in all environments, allowing for improved efficiency of vessel movements.
- It will give a better insight into the capabilities of the quays, potentially allowing larger vessels to be moored.
- Potentially reduces the requirement for expensive resources such as tugs, thanks to gathered data and predicted forces.
- Creates a long-term picture of the forces acting on the berths and vessels. This cumulative data can be used for port improvement projects, as well as continuous improvement of operations and processes.



The Smart Bollard is integrated into the MoorControl Software. This software is available in the cloud, accessible with every common browser. The dashboard provides all of the information necessary to fully use all capabilities of the Smart Bollard. The following data is displayed and stored:

- 1 **Load on bollard**
- 2 **Line direction**
- 3 **Line angle**
- 4 **Tide level**
- 5 **Weather data**
- 6 **Vessel history (AIS data)**

With a user-friendly interface, the administrator of the system can easily add users and set alarms. With the provided API all data can be accessed to be imported into other systems.

*The Smart Bollard is developed and tested in close cooperation with Port of Rotterdam*

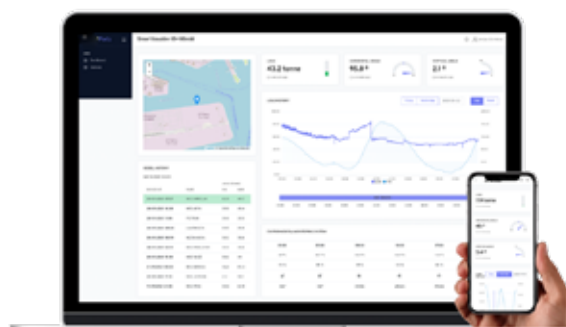

# Quick Release Towing Hooks

Our quick release towing hook, also known as a disc hook, is specially designed to guarantee safe operation on work boats, supply vessels, harbor, coastal, fire fighting and seagoing tugs. Our hooks can be equipped with all kinds of options. The GSH towing hook can be operated manually by means of a lever or a rope with a maximum effort of 15 kg at full load. A two-step release mechanism prevents accidental opening. It can be reset manually very easily, as the disc is counterbalanced. During the release, the rotation reduces the energy impact to a minimum.

## Options

- Spring loaded shock absorber.
- Customized designs.
- Local hydraulic or pneumatic release.
- Remote controlled release.
- Load monitoring system.
- Hook foundation / bracket / towing post.

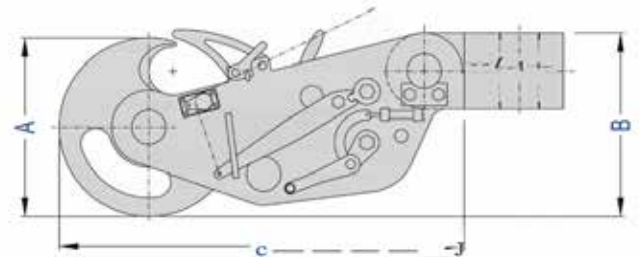
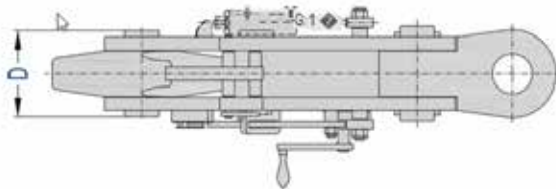

## QUICK RELEASE TOWING HOOK, TYPE GSH

	15 ton	25 ton	45 ton	65 ton	100 ton
A	340	470	470	600	650
B	340	473	483	599	670
C	765	1058	1063	1338	1465
D	152	196	226	268	322
Weight	150 kg	350 kg	470 kg	770 kg	1080 kg

# Tests and Certificates

All hooks are tested in our calibrated 3,500 kN hydraulic testing machine and we issue a test certificate as standard, as part of the user manual. If desired, the test can be witnessed by a classification authority of your choice.

Each quick release mooring hook will be proof load tested to 150% of the safe working load (SWL).

Each quick release towing hook will be proof load tested at 200% of the safe working load, with the exception of the GSH-100. This hook is tested at 150% of the safe working load (SWL).

All hooks undergo a release performance test at the safe working load.

All factory and witness test certificates will be provided as part of the user manual.

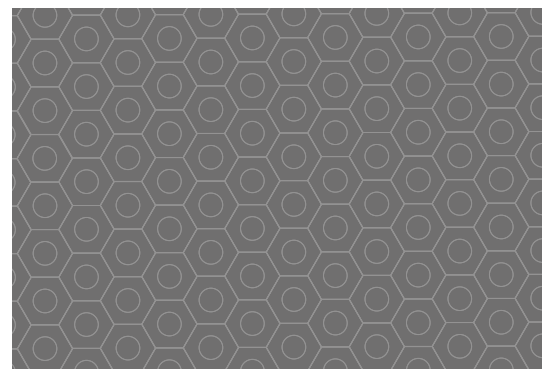

# Service & Support

---

## Design and manufacture

We design, engineer, manufacture and test our products at our own factory in the Netherlands. This keeps the lines short and enables us to maintain high quality products and efficient processes. Our skilled and experienced team are committed at every level and will be happy to discuss a solution with you.

## Commissioning and training

Our team of engineers ensure that installation and integration of our equipment runs smoothly, by offering an on-site commissioning service. In addition, we offer on-site training so that operators and key individuals know exactly how to use the equipment safely and correctly, and are able to resolve minor faults themselves. A bespoke training package can be provided as required.



## Inspection and maintenance

We offer a range of maintenance and service options for our products, and through experience would highly recommend considering a maintenance contract. As with most products, regular servicing and inspection will minimize breakdowns, identify minor issues before they develop, keep operators safe, and ultimately prolong the working life of the system.

## After-sales service

Our job doesn't stop after delivery and commissioning, we pride ourselves in our after-sales service. If you have any questions or issues regarding our equipment, we will offer full support, either by remote troubleshooting, or by using our call out service. We keep many spare parts in stock, and have a team of skilled engineers, so rapid support is always available. Rest assured, our team will always do the utmost to provide the best possible service along the way!



## Our network



Contact us for  
more information!

[www.mfstraatman.com](http://www.mfstraatman.com)



**Straatman B.V.**

Lindtsedijk 54

3336 LE Zwijndrecht

The Netherlands

+31 (0) 78 6125300

[info@mfstraatman.com](mailto:info@mfstraatman.com)



SPECIALIST PORT EQUIPMENT

+61 7 3177 3314

[info@speq.com.au](mailto:info@speq.com.au)

[www.speq.com.au](http://www.speq.com.au)